

# attwood® WaterBuster® Power Pump™ Cordless Water Pump, 4140

Attwood marine hardware, navigational lighting, bilge pumps, and other marine accessories are specified more than any other brand by America's best-known boat manufacturers as original equipment. Look to Attwood for quality replacement parts and marine accessories.

## SAVE THESE INSTRUCTIONS

Form Number 69243 Rev. F

03-10

## FEATURES:

The Attwood WaterBuster® Power Pump™ Cordless Water Pump is a compact, submersible pump. It is extremely handy around the dock, the house or farm. And, it's ideal for removing water from dinghies, inflatables, peddle boats and kayaks.

The Waterbuster will lift water to a maximum height of 4 feet and pumps in excess of 200 gallons per hour with fresh batteries.

The pump is made of high-impact plastic. It is completely portable and ready for use when 3 "D" size alkaline batteries are installed (batteries not included). It comes complete with a 42" hose and a male hose fitting for attachment to your garden hose.

U.S. Patent #5,094,591.

## OPERATING INSTRUCTIONS:

**IMPORTANT: To avoid airlock (flow stoppage), submerge pump in water before turning on. If pump must be turned on before being submerged, it may take 10-30 seconds for the water to begin to flow (allowing pump to clear airlock).**

- To install batteries, remove top cover of pump by turning the handle counter-clockwise (see Figure 1). Unplug the wire leads and remove battery retainer (see Figure 1 Detail). Insert three (3) alkaline "D" size batteries in position as indicated on the battery retainer. Replace battery retainer, re-attach wire leads, and lock cover into place (wire leads are different sizes to prevent improper wiring). The pump is completely portable and ready for use when batteries are installed.

Figure 1

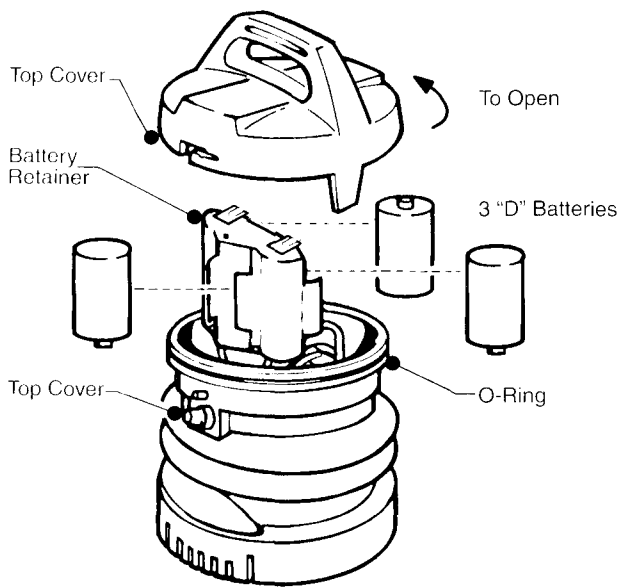
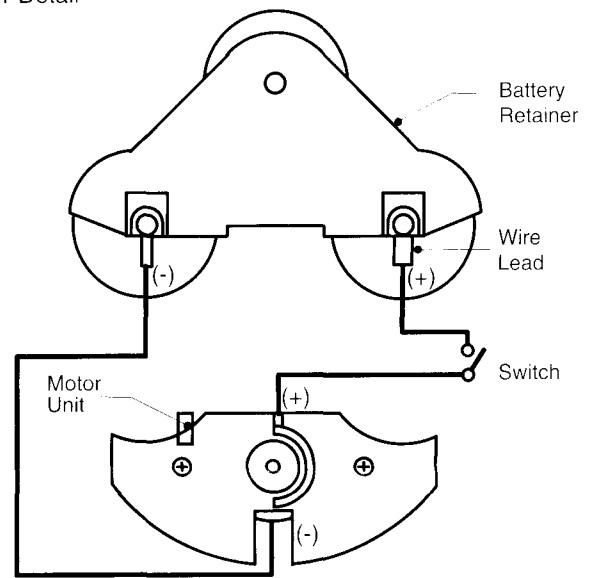

Figure 1 Detail



- Place pump into water at the deepest point possible. Make sure the pump is located in an area free of debris to avoid clogging. With bottom filter plate attached, pump will sink. If you wish pump to float, remove bottom plate by removing the two screws. The pump will then naturally float in an upright position.

**NOTE:** Floating the pump is desired when you wish to pump out an area that has debris at the bottom. See step 1 under Servicing Instructions. Some possible uses are: emptying aquariums without picking up aquarium gravel; filling a livewell with the same water as being fished; pumping out pools or reservoirs of greater depth than the pump hose length; and pumping basement sump reservoir to avoid sludge at the bottom.

**IMPORTANT: Keep pump tethered to prevent it from floating out of reach.**

- To start pump, push switch located directly below cover. Hold pump in position until the water begins flowing out of the hose. Check frequently to be sure water is flowing properly and pump is free from debris.
- If water is flowing slowly, check hose for kinks or debris. Turn pump off if it is necessary to remove debris. To remove debris simply remove pump from water and turn it upside down, looking for obvious obstructions. If further inspection is necessary, consult Servicing Instructions.

**NOTE:** After use, always flush the pump thoroughly with fresh clean water especially after pumping sea water or chlorine-treated water

## BATTERY & PUMP TIPS:

- Install fresh, name-brand alkaline batteries in this pump. While they may cost a bit more, tests have shown that they will run this pump continuously for up to 5 hours, while standard "D" batteries will last only 1/2 hour or less.
- Remove batteries from the pump when they are discharged or if the pump will be stored for an extended period. Discharged batteries occasionally leak, which will destroy the electrical circuit of the pump.
- Dispose of used batteries in a safe place. Follow battery manufacturer's recommendations. Do not burn them because they can explode. Do not throw in lakes, streams or rivers.
- Keep the inside of the pump dry at all times. If it does get wet inside, dry it immediately. A hair dryer held 12" away works well. Make certain the cover is tight before immersing the pump. Keep the O-ring lubricated with petroleum jelly.

## SERVICING INSTRUCTIONS FOR CLEANING OUT DEBRIS AND HOSE REPLACEMENT:

1. Turn the WaterBuster Power Pump upside down and remove the filter screen by removing the two screws with a Phillips screwdriver. Remove all debris.

**NOTE:** There are two extra screw holes in the screen that line up with a screw post in the pump. These were added for any extra support that you may need (see Figure 2).

Figure 2

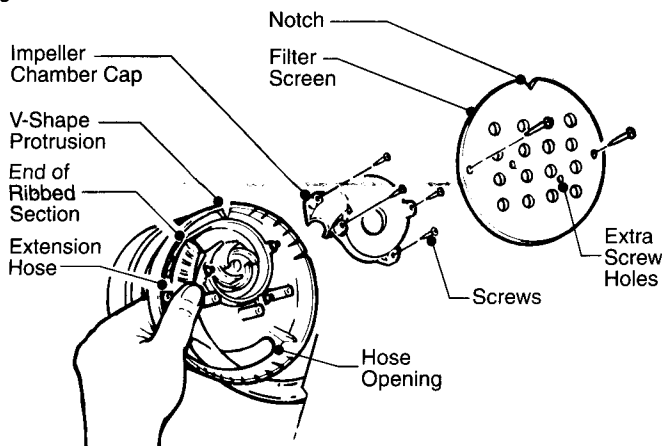

2. Remove the impeller chamber cover by removing all four screws. Remove all possible debris.

**NOTE:** The correct rotation of the impeller is counterclockwise, when viewing from the bottom of the pump. If the impeller rotates clockwise, or not at all, check the batteries for correct insertion.

3. When replacing the hose, remove impeller chamber cover (see Step 2 above). Remove existing hose and thread replacement hose clockwise through the hose opening in the pump housing.
4. Place the end of the hose to the end at the ribbed section of the impeller chamber (see Figure 2). Make sure there are no kinks in the hose.
5. To keep the hose in place, brace the hose with your thumb just outside the impeller chamber. Replace the impeller chamber cover and secure it by bracing your thumb on top of it. Replace and install screws. **DO NOT OVER TIGHTEN.**
6. Replace the filter screen by lining up the screw holes with the screw posts and the notch in the screen with the V-shaped protrusion in the pump housing. Replace and install screws. **DO NOT OVER TIGHTEN.**

## WARNINGS:

**This product is intended for pumping water only. Do not use to pump gasoline, diesel fuel or chemicals of any kind. Fluids other than water may destroy this product and/or create a fire hazard.**

**This portable pump is not intended for permanent installation in a bilge or sump area. It should not be used in situations where risk of personal injury or property damage could result from pump or battery failure.**

Do not use any power source other than three (3) "D" size alkaline batteries to power the pump.

Do not attempt to recharge batteries while installed in this product.

**NOTE:** To conserve batteries, you may use a siphon action (see Figure 3). The discharge end of the hose must be below the water level. To completely drain the water, it must be below the lowest water level. With the pump and hose as shown, turn the pump on until water flows, then turn the pump off. Water will continue to flow, but at a slower rate. This method can also increase the pumping rate with the pump turned on.

Figure 3

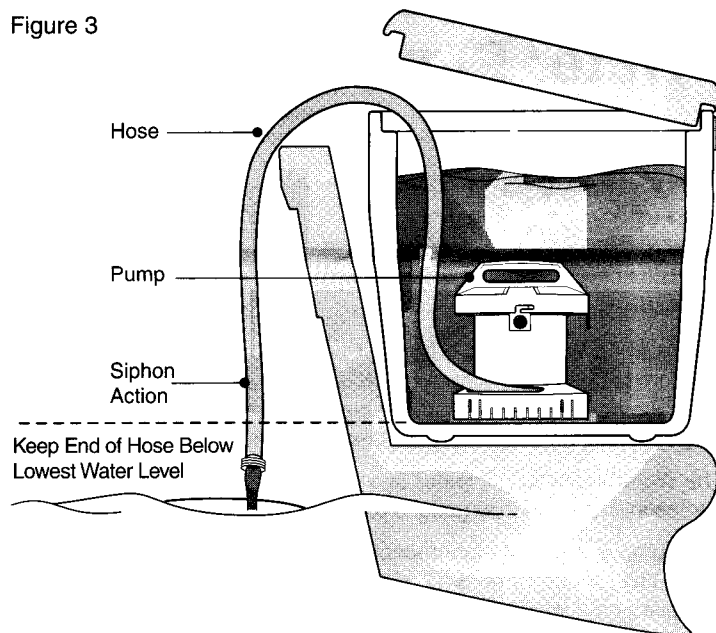

## ATTWOOD LIMITED WARRANTY

ATTWOOD CORPORATION, 1016 North Monroe, Lowell, Michigan 49331 ("Attwood") warrants to the original consumer purchaser that Attwood brand products will be free from defects in materials and workmanship under normal use and service for one year from the date of original consumer purchases.

This limited warranty is not applicable if the product has been damaged by accident, improper installation, unreasonable or improper use, lack of proper maintenance, unauthorized repairs or modifications, normal wear and tear, or other causes not arising out of defects in materials or workmanship.

Attwood products are warranted for use on pleasure boats. Any other use—including but not limited to commercial, racing, or non-marine use—are not covered under this warranty. Attwood's obligation under this warranty is limited to repair of the product at Attwood's plant or replacement of the products at Attwood's option without expense to the original consumer purchaser. Any expenses involved in the removal, reinstallation or transportation of the product are not covered by this warranty.

The product must be returned to Attwood's plant at the address above, postage pre-paid, and insured with proof of original purchase including date. If Attwood is unable to replace the product and repair is not commercially practical or cannot be timely made, or if the original consumer purchaser is willing to accept a refund in lieu of repair or replacement, Attwood may refund the purchase price, less an amount for depreciation. The acceptance by Attwood of any product returned or any refund provided by Attwood shall not be deemed an admission that the product is defective or in violation of any warranty. Products that are replaced or for which a refund is issued become the property of Attwood.

THIS WARRANTY IS ATTWOOD'S ONLY EXPRESSED WARRANTY OF THESE PRODUCTS. NO IMPLIED WARRANTY INCLUDING, WITHOUT LIMITATION, THE IMPLIED WARRANTIES OF MERCHANTABILITY AND FITNESS FOR A PARTICULAR PURPOSE, SHALL BE EXTENDED BEYOND THE WARRANTY PERIOD STATED ABOVE FOR EACH PRODUCT. ATTWOOD SHALL NOT BE LIABLE FOR ANY DAMAGES, FOR LOSS OF USE OF THIS PRODUCT, NOR FOR ANY OTHER INCIDENTAL OR CONSEQUENTIAL DAMAGES, COSTS, OR EXPENSES.

Some states do not allow limitations on how long an implied warranty lasts or the exclusion or limitation of incidental or consequential damages, so the above limitations and exclusions may not apply to you. This warranty gives you specific legal rights, and you may have other rights which vary from state to state.